

WE RESERVE ALL RIGHTS IN THIS DOCUMENT AND IN THE INFORMATION CONTAINED HEREIN. REPRODUCTION, USE OR DISCLOSURE TO THIRD PARTIES WITHOUT EXPRESS AUTHORITY IS STRICTLY FORBIDDEN.

Finish: Screw finish BVS 30 H 60
EN 16293

Front view

Back view

Bottom view

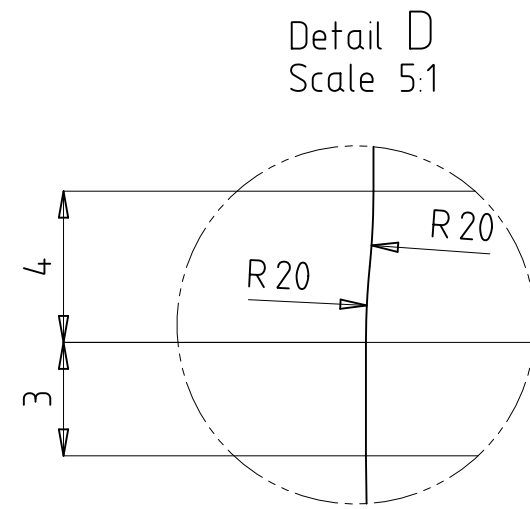
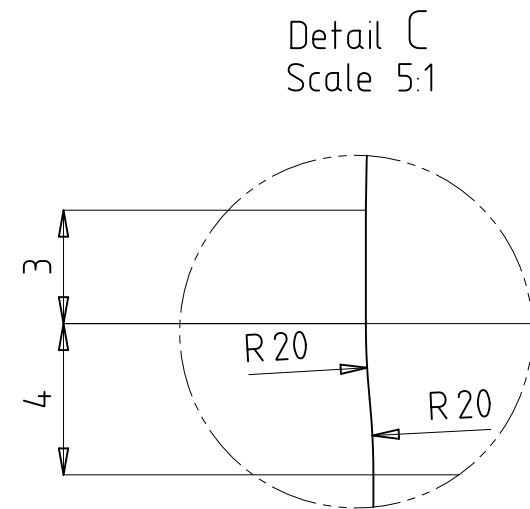
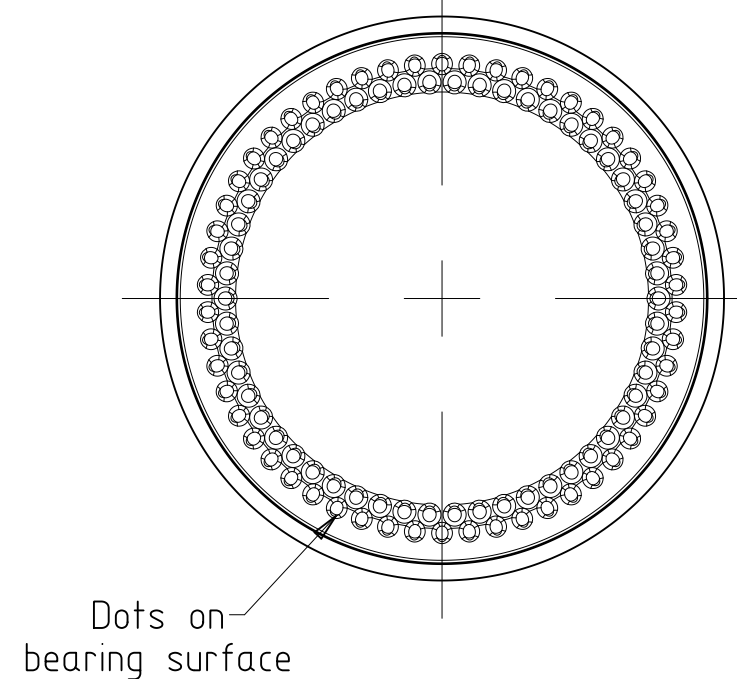
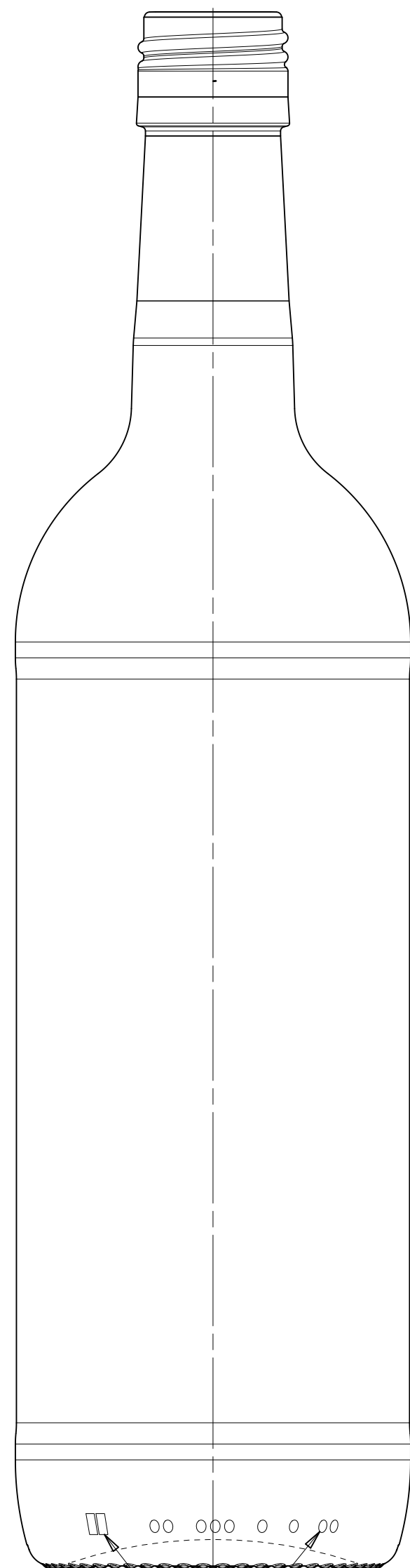
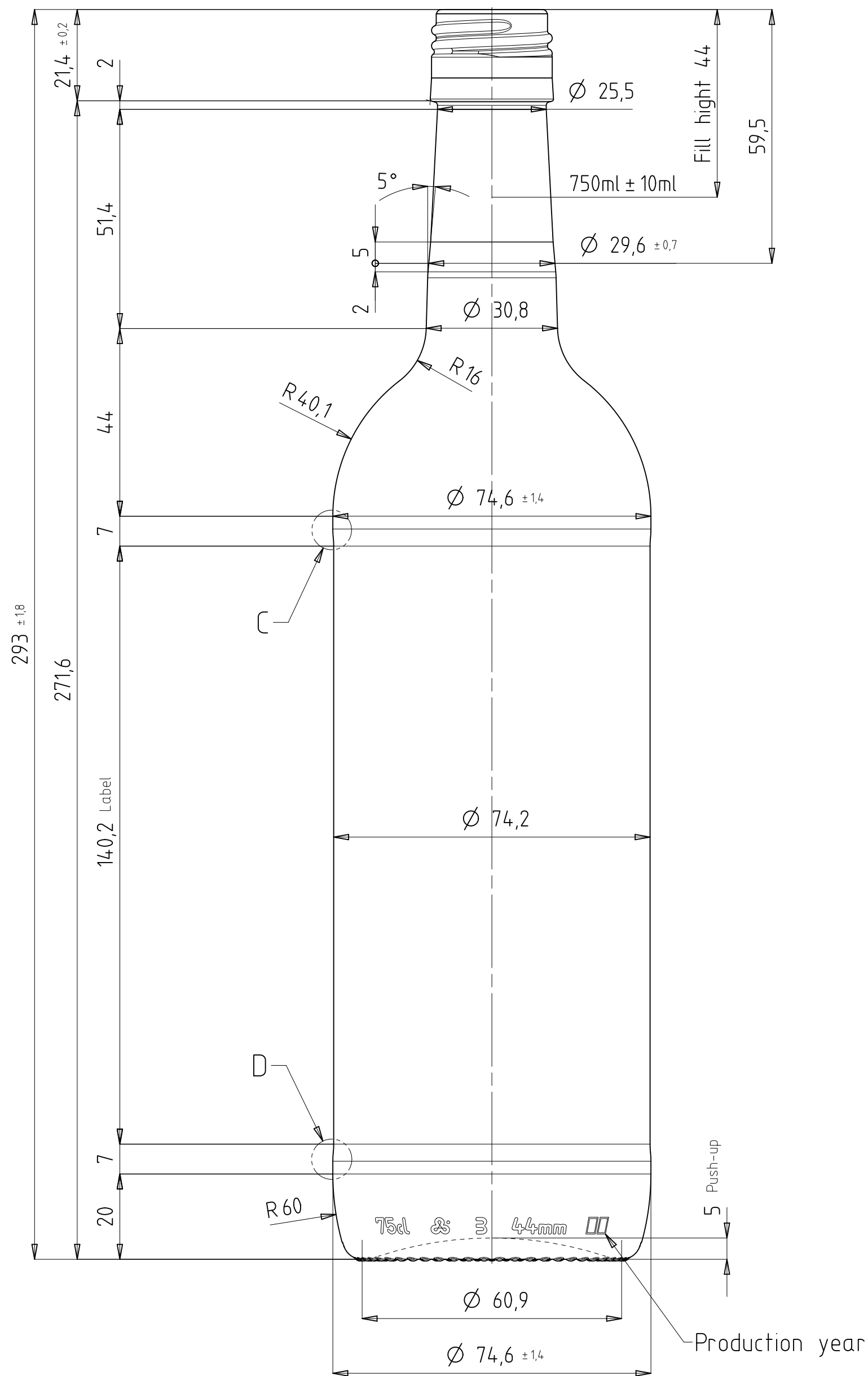

We declare our agreement with this drawing and the stated tolerances and hereby give our "Good for Execution".

06.05.25 Sol VMG

INDEX	ZMENY / modifications	DAT	JMENO	SOUHLAS TECHNOLOGA PT approved	DAT 10.02.25	VIS Roz	TEPLOTA PLNENI Filling temperature	≤ 15 °C	NOMINAL OBJEM Capacity fillpoint	750 ml ± 10 ml	POZNAMKA Remarks	WF 6125	
				SOUHVYR TYMU FIB approved	VYR.ZAVOD VMG	DAT 19.03.25	VIS Pre	TEPLOTA ZPRACOVANI Conditioning temperature	≤ °C	TOTAL OBJEM Capacity brimful	765 ml ± ml	ZAKAZNIK Customer	Standard
				FS SOUHLAS FS approved	VYR.ZAVOD VMG	DAT 21.03.25	VIS Haa	OBSAH CO ₂ CO ₂ content	≤ 4 g/l	HMOTNOST Approx glass weight	360 g	PODOBNY JAKO Similar to	
							OBSAH ALKOHOLU Alcohol content	≤ 16 Vol%	STREDNI TLOUSTKA STENY Average wall thickness	2,54 mm	NAHRAZUJE Replace No		
							AXIALNI ZATIZENI Axial pressure	600 daN	PRUMER POD USTIM Neck connection dia	25,5 mm	NABIDKA CISLO Offer No	E5W0124.0750.3772_B	
							POUZITI Disposal	MW AW EW	VNITRNI PRUMER KALIBRU Min through bore	17 mm	MERITKO Scale	1.1	
							PROCES Process	BB PB EPB	BARVA Color	OL	KRESLIL Des	PaM	
											DAT 06.01.25	DATA TYP Filetyp	AZ
												POZNAMKA Designation	BORDEAUX MOR ECO 360g BV3060 750ml BD ECO 360
												VYROBEK CISLO Item No	5W051.0750.3772
												INDEX	A

FÜR DIESES DOKUMENT UND DEN DARN DARGESTELLTEN GEGENSTAND BEHALTEN WIR UNS ALLE RECHTE VOR Vervielfältigen, Bekanntheit an Dritte oder Verwenden seines Inhalts sind ohne unsere ausdrückliche Zustimmung verboten.

Date: 06-Jan-25 Time: 13:14 Message: Vetropack to SAP released drawing: Original is archived at the designoffice